



Completely made and assembled in the U.S.A.

Sure Seal's Superior Encapsulated Design and Features

Sure Seal Series 899-892

Butterfly Valves

PATENTED

Sizes 1"-12" 125/150 ANSI

Interchangeable with Keystone
Figure 999 and 992

Elastomer Seat or Teflon® Seat Stainless Steel Disc
Teflon® Covered Seat with Teflon® Covered Disc
Elastomer Seat with Elastomer Covered Disc

SURE SEAL INCORPORATED IS PROUD TO BE



The Sure Seal Valve line comes with new and improved patented designs and concepts.

A Lot More Valve For A Lot Less Cost.



Sure Seal Series 899-892

Sizes 1"-12"

PATENTED

A Superior Sanitary Valve for the Chemical and Food Processing Industry

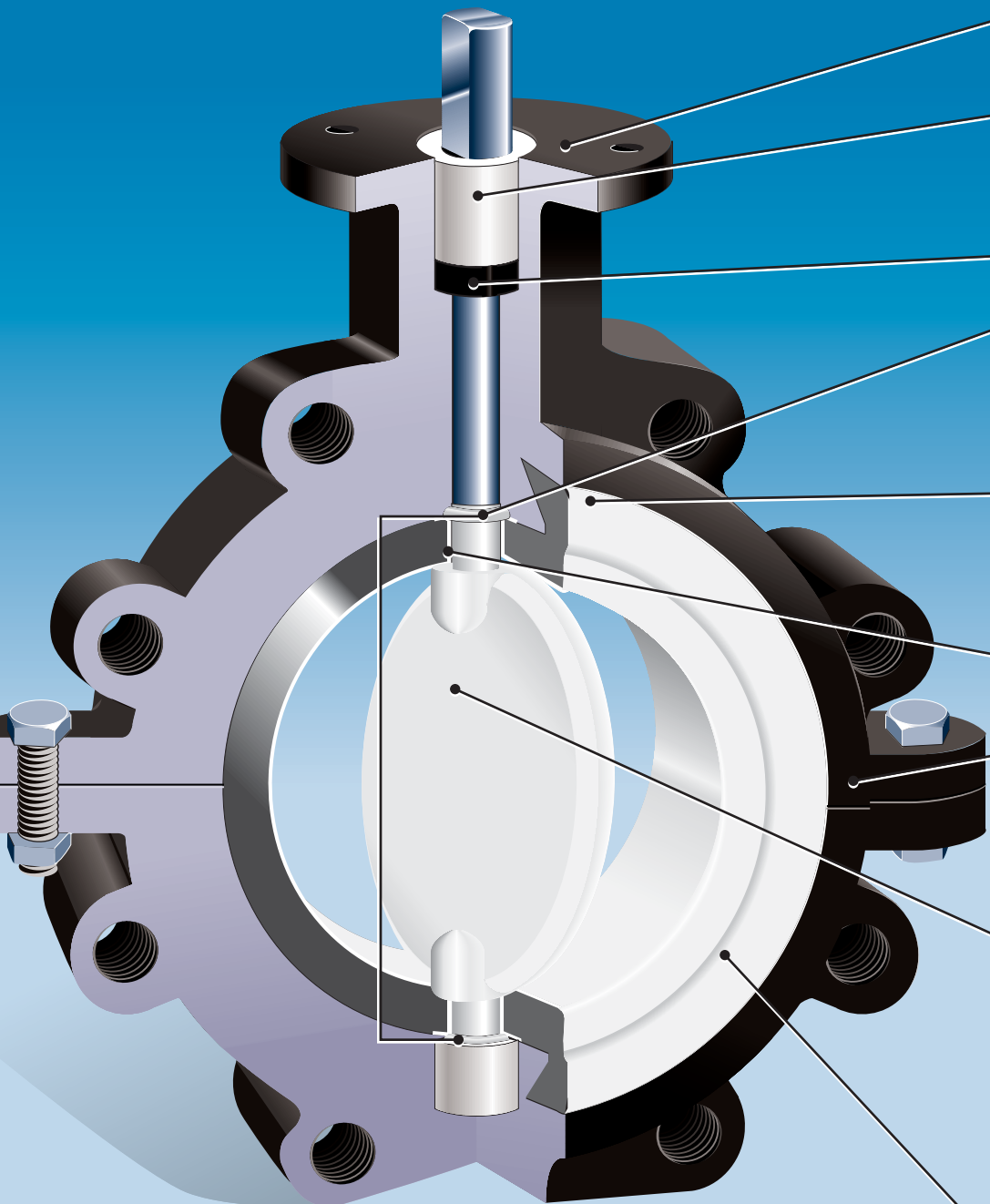

STANDARD FEATURES

Top Plate - Machined to standardized drilling pattern allowing manual handle kits, and actuation, interchangeability also available in ISO patterns.

Stem Bushing - Composed of full strength, corrosion resistant electrolyte, stem bushings absorb operator side thrust. Top bushing comes standard in all valves, while bottom bushing comes with all valves sizes 4"-12", to ensure trouble free valve operation.

Stem-Seal - A third seal ensuring absolute seal externally or internally for vacuum or pressure service. Available in Buna-N, EPDM, or Viton®.

O-Seal (patented) - Two Sure Seal O-Seals give a sure secondary seal as the O-Seal becomes part of the body and encircles the stem before entering the seat and disc area. O-Seals are also located at top and bottom of stem entry to form an absolute secondary seal. Available in Buna-N, EPDM, Viton®, or Teflon®.

Seat - EPDM, Viton®, and Sure Seal's Special Abrasion Resistant formulated blend of FDA approved Nitrile, along with 12 other standard compounds to meet your application. (PTFE) Teflon lined with EPDM, All Season Nitrile, Viton®, and other compounds to meet your needs.

Hub Seal or Primary Seal - Occurs when contact is made between the disc hub and the flat surface of the seat. Hub/seat seals prevent product from attacking stem or body.

Body - Lug style has drilled and tapped lugs meeting ANSI 125 and 150 flange standards. Two piece body allows ease of seat replacement. Lug body standard with Nodular Iron. Wafer body standard with Ductile Iron also available in Aluminum, Anodized Aluminum, Aluminum Bronze, Stainless Steel, Teflon® Coated and several Corrosion Resistant platings.

Disc/Stem - Sure Seal's standard is 255, a duplex stainless which is more corrosion resistant and almost twice as strong as all other butterfly valve manufacturers' standard 316 stainless steel. This eliminates shaft twisting and water hammer damage and allows a thin disc design which increases CV rating without reducing strength. All encapsulated disc stems are 255 duplex stainless as standard which gives you approximately four times the corrosion resistance as 316 stainless steel and more strength too. Other materials are also available.

Flange Seal - Sealing O-Ring of resilient seat which provides an absolute seal to all flanges within specifications.

Patent #5207411

Every valve is tested to 110% of full pressure rating.

Teflon® and Viton® are registered trademarks of E.I. DuPont Co.

The Difference Between Our Encapsulated Valve and Theirs? It's Night and Day.

Without Sure Seal's Superior Encapsulated Design Product and/or cleaners can enter into the stem hole and attack the seat and stem.

The Reason Why Sure Seal is the Superior Encapsulated Valve on the Market Today.

The superior encapsulated design and features offer more than any other butterfly valve manufacturer on the market today. Sure Seal's Teflon® lined valve seat extends all the way through the shaft hole to the patented Teflon® O-Seal. The Teflon® encapsulated disc stem extends all the way through the Teflon® lined seat to the Teflon® O-Seal with no exposed rubber backing or metal disc stem like other manufacturers. Sure Seal's encapsulated disc and stems are made of superior 255 stainless steel which is far more corrosion resistant and stronger than other manufacturers standard 316 stainless steel encapsulated disc stem which stops stem twisting and water hammer damage. Sure Seal offers a wide variety of rubber backings for lined seats including Viton®. Sure seal also offers elastomer encapsulated disc stems with its special blend of FDA approved nitrile for superior abrasion resistance also available in EPDM and numerous other materials. Sure Seal's standard 255 stainless steel one piece disc stem is so much more corrosion resistant then other butterfly manufacturers 316 stainless steel one piece disc stem you may be able to reduce your cost by not needing a full Teflon® valve to do the job.

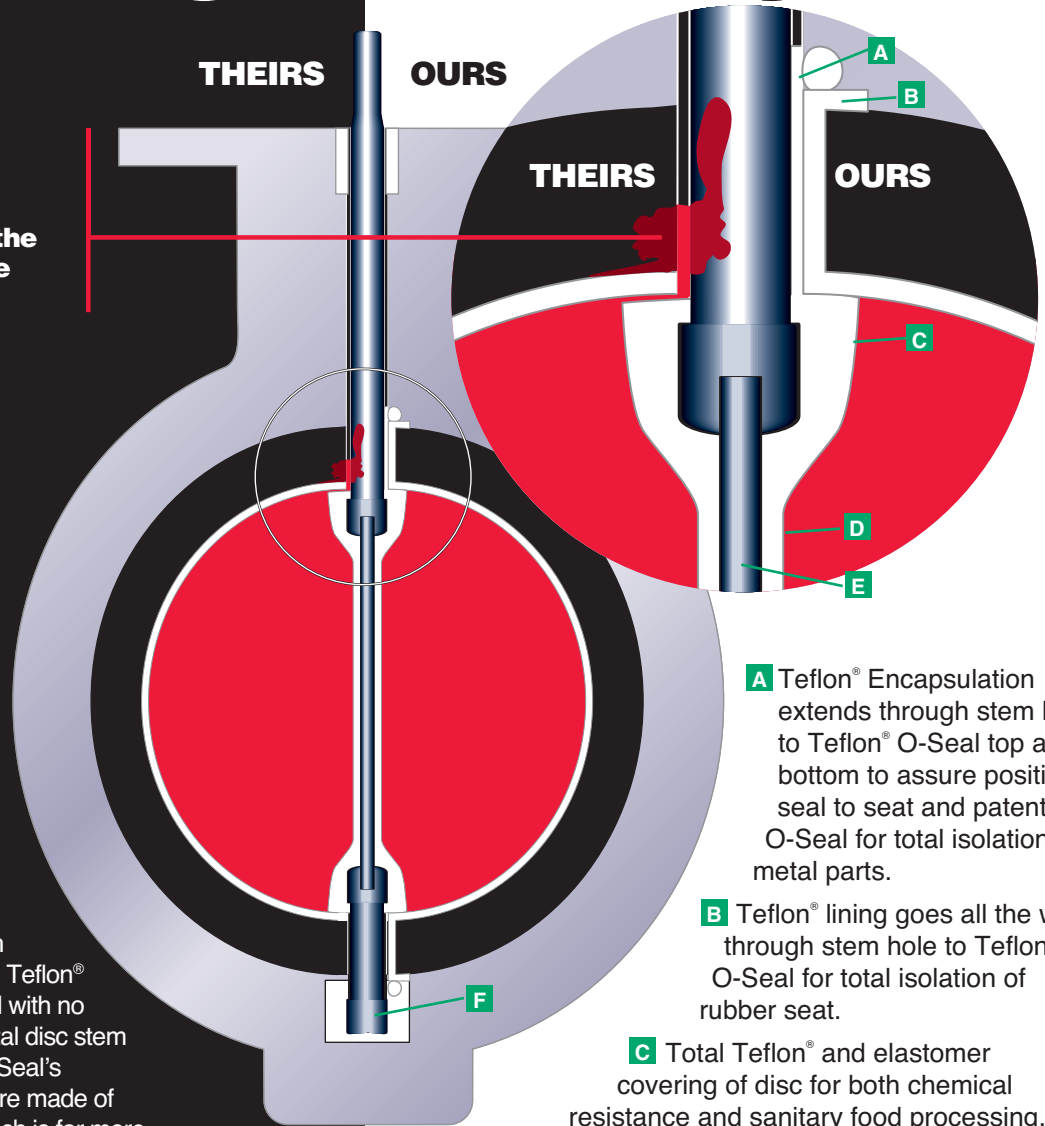

A Teflon® Encapsulation extends through stem hole to Teflon® O-Seal top and bottom to assure positive seal to seat and patented O-Seal for total isolation of metal parts.

B Teflon® lining goes all the way through stem hole to Teflon® O-Seal for total isolation of rubber seat.

C Total Teflon® and elastomer covering of disc for both chemical resistance and sanitary food processing.

D Slim disc for maximum flow.

E Sure Seal's one piece disc and stem is standard 255 stainless steel which is several times more corrosion resistant and stronger than other manufacturers 316 stainless steel.

F Precision machined stems top and bottom to assure the proper seal and alignment to the ertalyte bushing with patented O-Seals for total secondary seal.



The reason why Sure Seal is clearly the Superior Butterfly Valve on the Market Today

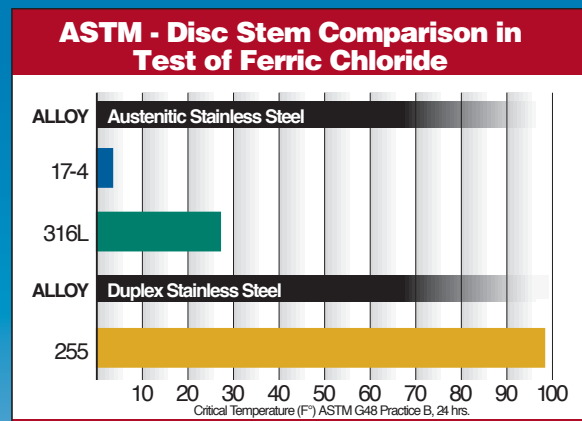
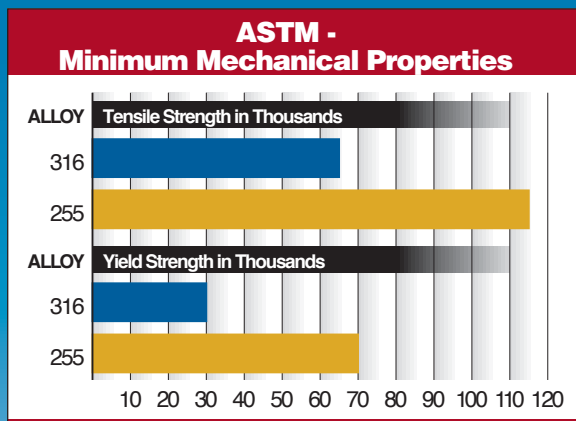

Sure Seal's standard is a 255 duplex stainless which is more corrosion resistant and almost twice as strong as all other butterfly valve manufacturers standard 316 stainless steel. This eliminates shaft twisting and water hammer damage which other butterfly valve manufacturers have to make their disc thicker to handle water hammer which also reduces the CV of their valve. With Sure Seal's standard no other valve has higher CV's with this super thin disc design and the strength to handle the service. Other materials also available.

Bar graph above is showing a comparison of the ASTM minimum mechanical properties of 316 stainless steel to 255 stainless steel. Bar graph above right is showing Sure Seal's standard disc stem material 255 to other manufacturers optional 316L and 17-4 disc stem in an ASTM test of Ferric Chloride, a common method of comparing corrosion resistance in stainless steels.



The chemical and food processing industry needed a truly sanitary valve and with Sure Seal's patented O-Seals they got just that. As the O-Seal seals at the back side of the seat top and bottom and also at the stem entry top and bottom it forms an absolute seal making it the truly sanitary valve on the market today. O-Seals are available in Buna-N, EPDM, Viton® and

Teflon®. In either wafer style 890 or a full lug body 893 drilled and tapped for 125 to 150 ANSI flanges. With Sure Seal's slim disc design no other valve has higher CV's and with rounded, hand polished disc and hub edges reduce friction torque to maintain seat life. Seats are available in 14 different compounds including Sure Seal's special FDA approved All Season nitrile which can handle temperatures from 300° to -40° and still stay resilient, flexible, and very abrasion resistant. Now you can save on valves and replacement parts for your existing valves.

Sure Seal's 890/893 are dimensionally interchangeable with Keystone 99/993 and Ultraflo 390/393.

TEFLON® NXT



Improve the performance of your valves by upgrading to a Teflon® NXT encapsulated valve.

Teflon® NXT exhibits the superior properties typical of the fluoropolymer resins: nonaging characteristics, chemical inertness, heat resistance, toughness and flexibility, low coefficient of friction, non-stick characteristics, negligible moisture absorption, weather resistance and increased resistance of permeation of chemicals.

- Smoother, less porous surfaces - Teflon® NXT provides a smooth, glossy surface with low porosity. There's virtually no place for contaminants to get a grip. Plus, Teflon® NXT resists shedding of particles.
- Reduced Permeation - Due to the low micro void content of Teflon® NXT it shows improved resistance to chemical permeation compared with standard PTFE.
- FDA Compliance - Teflon® NXT resin can qualify for use in contact with food in compliance with FDA Regulation 21 CFR 177.1550.

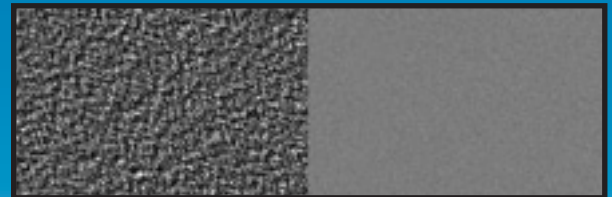

This electron photomicrograph shows sheet skived from a billet of conventional PTFE (at left) welded to Teflon® NXT (at right). The weld line (middle) shows the polymers are intimately joined. Thanks to its smoothness, sheet of Teflon® NXT resists shedding of particles, and with lower porosity, it is less likely to trap contaminants.

Comparative Permeation Rates for Teflon® NXT and Conventional PTFE

Permeant	Specimen Thickness, mm (in)	Vapor		Liquid		Gas	
		PTFE	Teflon® NXT	PTFE	Teflon® NXT	PTFE	Teflon® NXT
Perchloroethylene	1 (0.04)	5.5	2	13	4	-	-
Perchloroethylene	2 (0.08)	1.4	0.1	0.019	0.005	-	-
Perchloroethylene	4 (0.16)	0.08	0.05	0.006	0	-	-
Perchloroethylene	5 (0.20)	0.055	0.050	-	-	-	-
Hexane	2 (0.08)	3.4	0.2	23.4	0	-	-
Hexane	5 (0.20)	0.045	0.015	-	-	-	-
MEK	2 (0.08)	36.3	23.3	49.4	34.2	-	-
MEK	5 (0.20)	22.6	20.8	35.5	25.2	-	-
HCl, 20%	1 (0.04)	0.4	0.1	-	-	-	-
Helium	2 (0.08)	-	-	-	-	93	1
Helium	5 (0.20)	-	-	-	-	0.18	0.12

Sure Seal Series 899/892

Sure Seal Series 899/892 are dimensionally interchangeable with Keystone Fig. 999/992

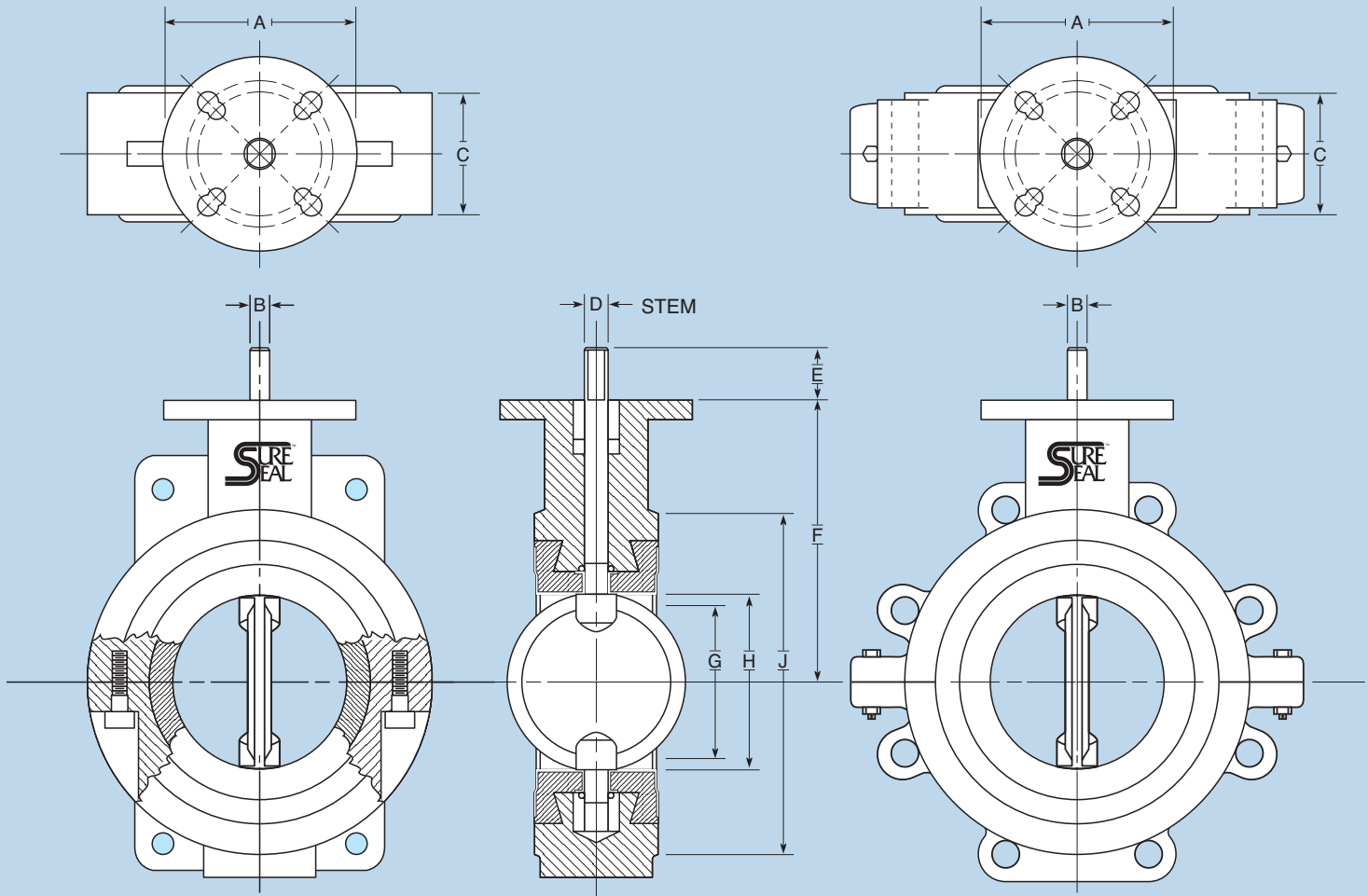

Valve Size

	1	1.5	2	2.5	3	4	5	6	8	10	12
A	2.560	2.560	4.000	4.000	4.000	4.000	4.000	4.000	6.000	6.000	6.000
B	.250	.250	.375	.375	.375	.438	.500	.500	.625	—	—
C	1.125	1.188	1.625	1.750	1.750	2.000	2.125	2.125	2.500	2.500	3.000
D	.375	.375	.563	.563	.563	.625	.750	.750	.875	1.125	1.125
E	.750	.750	1.250	1.250	1.250	1.250	1.250	1.250	1.250	2.000	2.000
F	3.540	4.120	3.938	4.500	4.875	6.000	6.000	6.500	8.313	9.000	10.625
G	.625	1.438	1.375	2.063	2.563	3.625	4.750	5.500	7.500	9.594	11.563
H	1.188	1.750	2.000	2.500	3.000	4.000	5.000	5.750	7.750	9.750	11.750
J	2.437	3.218	4.125	4.825	5.250	6.750	7.625	8.625	10.812	13.375	16.188

GENERAL NOTES:

C = INSTALLED WIDTH

G = MINIMUM ALLOWABLE INSIDE DIA. OF PIPE OR MATING FLANGE

1"-8" — D = STEM CONNECTION DIA.; B = FLATS

10" - 12" — D = STEM CONNECTION DIA.; KEYWAY = .250 X .250

* Weight based on 255 Stainless Steel disc/stem and Cast Iron Body.

VELOCITY LIMITS:

*FOR ON/OFF SERVICES

FLUIDS - 9 M/S (30 FT/SEC) GASES - 54 M/S (175 FT/SEC)

Top Plate Drilling

STANDARD	1	1.5	2	2.5	3	4	5	6	8	10	12
No. Holes	N/A	N/A	4	4	4	4	4	4	4	4	4
Bolt Circle	—	—	3.250	3.250	3.250	3.250	3.250	3.250	5.000	5.000	5.000
Hole Dia.	—	—	.438	.438	.438	.438	.438	.438	.563	.563	.563

ISO	1	1.5	2	2.5	3	4	5	6	8	10	12
No. Holes	4	4	4	4	4	4	4	4	4	4	4
Bolt Circle	1.970	1.970	2.760	2.760	2.760	2.760	2.760	2.760	4.020	4.020	4.020
Hole Dia.	.281	.281	.375	.375	.375	.375	.375	.375	.406	.406	.406

NOTES: Both Standard and ISO drillings come on each valve.

Weight in Pounds*

	1	1.5	2	2.5	3	4	5	6	8	10	12
899	2	4	6	8	9	11	15	17	29	44	85
892	N/A	N/A	8	10	11	17	21	26	42	65	108

Wafer Bolt Circle and Tapped Lug Data

	1	1.5	2	2.5	3	4	5	6	8	10	12
Bolt Circle	3.125	3.875	4.750	5.500	6.000	7.500	8.500	9.500	11.750	14.250	17.000
No. Holes	4	4	4	4	4	8	8	8	8	12	12
Tap	N/A	N/A	.625-11 UNC				750-10 UNC			.875-9 UNC	

Purchasers are expected to make their own tests to determine the suitability of these products for their particular purposes. The data represented in this flyer is for general information only. Manufacturer is not responsible for acceptability of these products in regard to individual system requirements. For specific performance data and correct materials selection, please contact your Sure Seal Dealer. ©2001 Sure Seal, Incorporated • Printed in the USA

Rt. 2, Box 2242 • Mineral Point, Missouri 63660 • (573) 438-5000 • Fx (573) 438-4853
www.suresealinc.com • ssi@suresealinc.com

1-800-382-1604

